

TWD1683VE

16.12 liter, in-line 6 cylinder - 585 kW
EU Stage V



TWD1683VE is a powerful, reliable and fuel efficient off-road Diesel Engine built on the Volvo in-line six concept.

Low cost of ownership

World class fuel efficiency combined with a reliable Exhaust Aftertreatment System (EATS) gives high uptime as well as low cost of ownership.

Compact & simple installation

The TWD1683VE engine will have a two stage turbo system, common rail fuel system and a water cooled charge air system for better fuel efficiency. Installation guidelines as well as drawings and CAD models are easy to access.

Material needed in order to install the engine can be ordered as optional equipment from Volvo Penta. The result is an engine and EATS that is easy to install and operate.

Durability & low noise

Long experience with SCR systems in combination with great knowledge of base engine development reduces risk of downtime. The in-line six cylinder engine together with common rail system produces smooth operation with low noise.

Power & torque

Outstanding response performance with maximum torque available at low rpm that continues to nominal power. The power and torque layout ensures the engine to operate in a wide engine speed range.

Low exhaust emission

Chosen engine design combined with optimized SCR only technology ensures that TWD1683VE complies with EU Stage V emissions.

Easy service & maintenance

Easily accessible service and maintenance points contribute to the ease of service of the engine. As optional equipment remotely mounted filters and service points can be chosen.

- Proven and straight-forward design - built on Volvo Group technology
- High torque already at low engine speed
- SCR only
- Compact, simple installation and easy to service
- Same engine footprint for all emission standards
- Wide range of optional equipment
- Extended oil service intervals 1000h

Power output as per ISO 14396, kW/hp 585/796

at speed, rpm 1900

Max. torque, Nm/lb/ft 3650/2692

at speed, rpm 1200

Min. idling speed, rpm 600

TWD1683VE

16.12 liter, in-line 6 cylinder - 585 kW
EU Stage V

Technical data

Configuration and no. of cylinders	in-line 6
Displacement, l (in ³).....	16.12 (984)
Method of operation	4-stroke
Bore, mm (in.)	144 (5.67)
Stroke, mm (in.)	165 (6.50)
Wet weight [*] , engine only, kg (lb)	1726 (3805)
Compression ratio.....	16.8:1
Direction of rotation (viewed towards flywheel).....	counterclockwise

^{*}) The weight includes: engine coolant, engine oil, engine mounted filters, flywheel, 110A alternator, cac, cac pump, no compression brake, no airfilter, no air compressor, no ac compressor and no cooling system.

Technical description

Engine and block

- Cast iron cylinder block
- Wet, replaceable cylinder liners
- Replaceable valve guides and valve seats
- Overhead camshaft and four valves per cylinder

Lubrication system

- Full flow disposable spin-on oil filter, for extra high filtration
- Gear type lubricating oil pump, gear driven by the transmission
- Oil level sensor at startup

Fuel system

- Electronically controlled common rail system
- Fuel pre filter with water separator and water-in-fuel indicator/alarm
- Gear driven low-pressure fuel pump
- Fine fuel filter with manual feed pump and fuel pressure valve

Cooling system

- Belt driven coolant pump with high degree of efficiency
- Water-cooled charged air cooling system

Turbo charger

- Two stage turbo system
- Electronically controlled bypass-valve

Electrical system

- Engine Management System (EMS) 2.4, includes advanced features for diagnostics and fault tracing.
- The instruments and controls connect to the engine via the CAN SAE J1939 interface. Options available for engine control equipment.

Exhaust after treatment system

- SCR only
- Airless urea injection
- Wide range of options available, including different sized AUS/DEF tanks (also possible for OEM to design own tank).
- AUS/DEF Quality Level Temperature Sensor

Dimensions

Not for installation. Dimensions in mm.

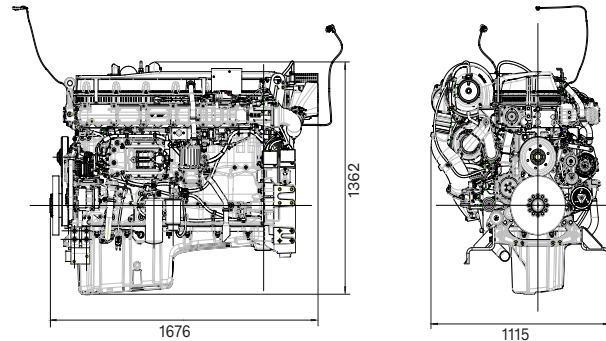

Please note that products illustrated may differ from production models.

Not all models and accessories are available in all markets, and standard equipment may vary between different markets. Every effort has been made to ensure that facts and figures are correct at the time of publication. However, Volvo Penta reserves the right to make changes without prior notice at any time.

Main components

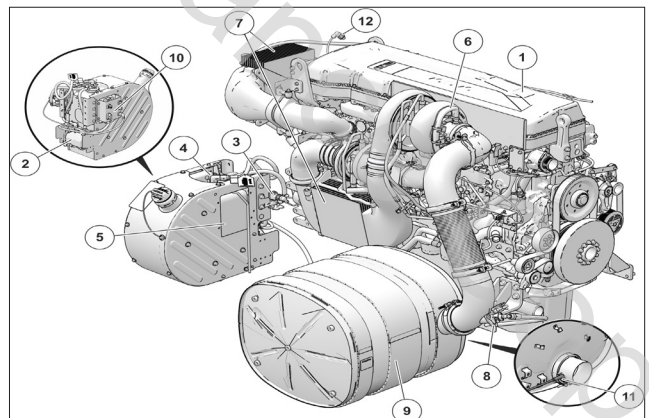

- | | |
|--|--|
| 1. Engine with common rail fuel system | 8. Urea dosage Valve |
| 2. AdBlue Pump Unit | 9. Muffler with Catalytic Converter |
| 3. Solenoid Valve, urea tank heating | 10. After treatment Control Module (ACM) |
| 4. Tank armature with sensors and heater element | 11. NOx Sensor |
| 5. AdBlue tank | 12. Air inlet Temperature Sensor and pressure sensor |
| 6. NOx Sensor | |
| 7. Water-cooled charged air cooling system | |

All necessary components are available in various lengths and sizes, cables, heated hoses and tanks. A complete system.

Characteristics

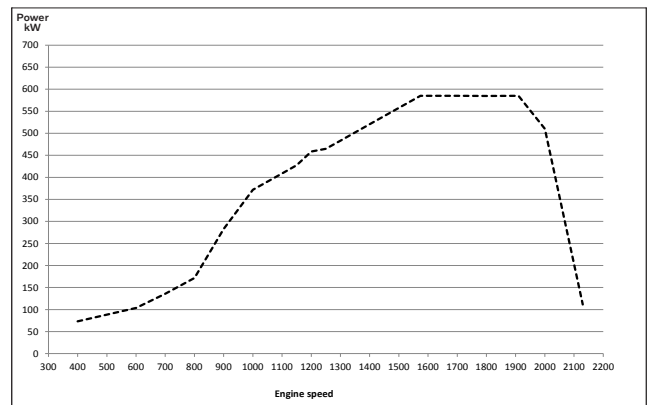

VOLVO PENTA

AB Volvo Penta

SE-405 08 Göteborg, Sweden
www.volvopenta.com